

X-TRONIC USA

Soldering Technology
Professionals Can Trust



5040-XR3 Instructions

TABLE OF CONTENTS

Product Specifications	2
Package Contents	3
Safety Precautions	4
Initial Set-up	5
Unit Interface	6
Operating Instructions	8
Features	10
Celsius / Fahrenheit Conversion	10
Automatic / Manual Mode.....	10
Calibration Function	11
Maintenance	14
Unit.....	14
Soldering Tip Preparation & Care.....	14
Changing the Soldering Tip	15
Install/Remove Hot Air Nozzles	15
Replacing the Soldering Iron Heating Element	16
Replacing the Hot Air Gun Heating Element	17
Troubleshooting	18
Warranty	20
Contact Information	22

PRODUCT SPECIFICATIONS

MODEL #5040-XR3	
Power Consumption	1270 Watts \pm 5%
Dimensions	8.7 x 3.1 x 12.6 in / 22.1 x 7.9 x 32.0 cm
Weight	6.6 lbs / 3.0 kg
Working Environment	32°F ~ 122°F / 0°C ~ 50°C
Storing Environment	-68°F ~ 176°F / -20°C ~ 80°C
HOT AIR REWORK	
Airflow Type	Brushless Fan (Spiral Wind)
Airflow Volume	31 L/min
Temperature Range	212°F ~ 896°F / 100°C ~ 480°C
Temperature Stability	\pm 1°C
Cord Length	\geq 39.4 in / 100 cm
SOLDERING IRON	
Temperature Range	392°F ~ 896°F / 200°C ~ 480°C
Temperature Stability	\pm 1°C
Grounded Tip Voltage	< 2 mV
Tip Impedance	< 2 Ω
Cord Length	\geq 39.4 in / 100 cm
PREHEATING STATION	
Temperature Range	122°F ~ 752°F / 50°C ~ 400°C
Temperature Stability	\pm 2°C
Heating Area	4.7 in x 4.7 in / 12 cm x 12 cm

PACKAGE CONTENTS

- 1 – X-Tronic #5040-XR3 Multifunction Main Unit
- 1 – X-Tronic Soldering Iron with 900M-T-I Tip Installed
- 1 – X-Tronic Hot Air Gun
- 1 - Soldering Iron Holder
- 1 - Blue Wet Cleaning Sponge
- 1 - Solder Roll Holder
- 1 – Stainless Steel, Anti-static Tweezers
- 1 – Wick De-soldering Braid
- 1 - IC Popper
- 4 – Hot Air Nozzles (Assorted Sizes & Shapes)
- 9 – Soldering Iron 900M Tips Variety Pack
 - 900M-T-I
 - 900M-T-B
 - 900M-T-K
 - 900M-T-1C
 - 900M-T-2C
 - 900M-T-3C
 - 900M-T-1.2D
 - 900M-T-1.6D
 - 900M-T-2.4D

SAFETY PRECAUTIONS

1. When initially powering on the unit and when powering down, the hot air gun should ALWAYS be in the side holder. It should NEVER be in the vertical position when the unit is initially turned on. If it is used vertically with the appropriate air flow, it MUST be returned to the side holder for cool down.
2. When using the hot air gun in the vertical holder the air flow MUST be turned up to at least 4 or higher the entire time the hot air gun is in this position. If the air flow is not sufficient the life of the heating element will be greatly reduced.

CAUTION! IF #2 IS NOT FOLLOWED

The hot air gun will overheat and may cause the polymer on the front of the hot air gun to melt and get red hot from the intense heat.

3. Never use the soldering iron or the hot air gun near any flammable substance, material, or gas.
4. Never touch the metallic components of the soldering iron or the hot air gun while they are in use. They are extremely hot and will cause serious burns instantly. Allow the unit to properly cool to room temperature before attempting to touch them.
5. Never point the hot air gun towards human skin. The air exiting the hot air gun is VERY HOT and WILL cause serious burns.
6. Do not use pliers or any other tool to manipulate hot air nozzles.
7. Do NOT try to reform nozzle attachments into other shapes.
8. Never place anything flammable on or near IR Preheating Plate.
9. Never Touch the IR Preheating Plate or surrounding chassis while in operation.
10. Ensure a minimum distance of 2mm while using the hot air gun in the hands-free telescopic hot air gun holder.
11. Always keep the hot air gun moving, unless reflowing large chips.

INITIAL SET-UP

1. Unpack all of the contents of the X-Tronic #5040-XR3 kit.
2. Inspect the unit and accessories for any damage. If damage is detected, please contact X-Tronic immediately.
3. Assemble the hands-free telescopic hot air gun holder

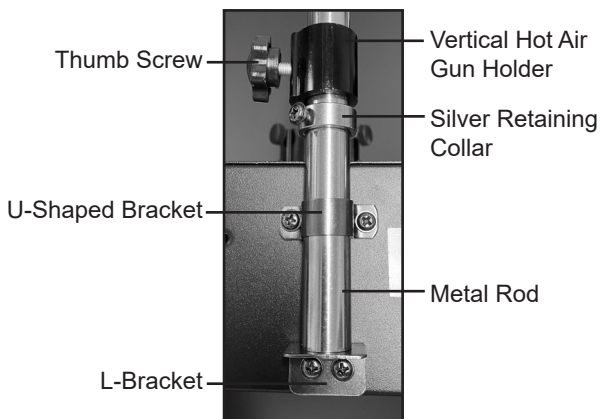

Note: The Vertical Hot Air Gun Holder and Silver Retaining Collar will be further up on the Metal Rod when fully assembled.

- a. Slide the silver retaining collar onto the metal rod. Install one of the small dark gray screws into the hole on the silver retaining collar to secure its placing on the metal rod.
 - b. Attach the L-bracket to the bottom of the metal rod using the large silver screw.
 - c. Attach the L-bracket and rod assembly to the back of the unit using the 2 holes in the lower center and 2 of the smaller dark gray screws.
 - d. Secure the rod to the back of the unit using the U-shaped bracket and the last two of the smaller dark gray screws.
 - e. Slide the vertical hot air gun holder assembly over the rod and secure it with the included thumb screw. Adjust the silver retaining collar so it is just below the hot air gun holder assembly to provide additional support.
 - f. Insert the 4 black thumb screws into the adjustable rail system around the IR Preheating Plate.
4. Attach the soldering iron to the unit using the soldering iron connection.
 5. Place the soldering iron into the soldering iron holder.

6. Attach the hot air gun holder to the side of the unit using the 2 screws that are in the side of the unit.
7. Place the hot air gun into the hot air gun holder.
8. Ensure all of the connections are secure and correct before applying power to the unit.
9. Ensure the safety fuse (found on the back of the unit above the power receptical) is installed and in good working order before applying power to the unit.
10. Plug the power cord into a GROUNDED AC wall outlet.
11. Turn on the main power switch located on the back of the unit.
12. Power on the unit.
 - a. Soldering Iron
 - i. Attach the desired tip to the soldering iron.
 - ii. Power on the soldering iron with the Iron power switch.
 - iii. Adjust the soldering iron temperature by pressing the soldering iron ↑ and ↓ buttons.
 - b. IR Preheating Station
 - i. Power on the preheating plate with the IR Preheating Plate switch.
 - ii. Adjust the preheating plate temperature by using the IR preheating Plate ↑ and ↓ buttons.
 - c. Hot Air Gun
 - i. Attach the desired nozzle to the hot air gun and place the hot air gun in the side holder.
 - ii. Turn on the hot air gun by with the Hot Air power switch.
 - iii. Adjust the hot air temperature by using the hot air gun ↑ and ↓ buttons.

USER INTERFACE

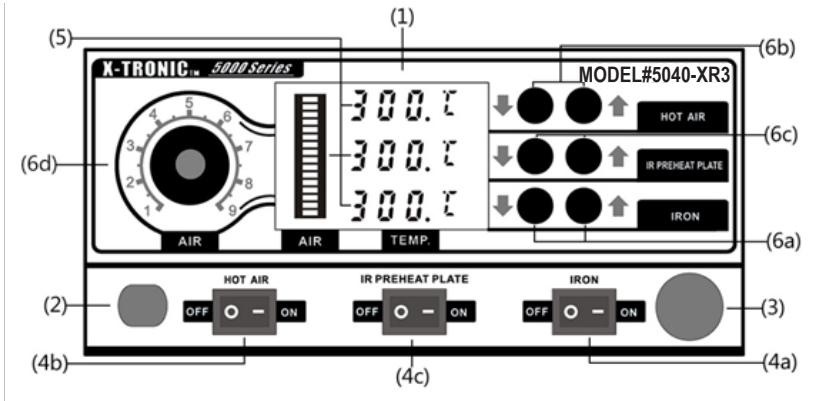

1. X-Tronic #5040-XR3 Main Unit
2. Hot Air Gun Receptical (Hardwired)
3. Soldering Iron Receptical
4. Power Switches
 - a. Soldering Iron
 - b. Hot Air Gun
 - c. IR Preheating Plate
5. Temperature Displays
6. Adjustment
 - a. Soldering Iron Temperature
 - b. Hot Air Temperature
 - c. IR Preheating Plate Temperature
 - d. Air Speed

OPERATING INSTRUCTIONS

SOLDERING IRON

- Before turning on the unit, ensure that the soldering iron is in the soldering iron holder and the hot air gun is in the hot air gun holder on the side of the unit.
- When using the soldering iron for the first time, be sure to allow the iron to come to the proper temperature then clean and tin the tip to provide longer life expectancy.
- Do not use excessive force when installing/removing soldering iron tips.

HOT AIR GUN

- Before turning on the unit ensure that the hot air gun is in the hot air gun side holder. The hot air gun needs to be in this position **EVERY TIME** the unit is powered on.



**Hot Air Gun
Side Holder**

- Upon first use, the tube on the soldering iron may discolor a bit due to the combination of the material composition and high heat. This is perfectly normal and expected behavior.
- Upon first use, white smoke may be visible from the hot air gun and will go away shortly after heating. If the unit keeps smoking, refer to troubleshooting section or contact X-Tronic International (contact information is on the back cover of this manual).
- When “---” is displayed on the LED display, the outlet temperature of the hot air gun is below 100°C, the handle has been properly replaced into the side holder, and the unit is in standby mode.
- Do not use excessive force when installing/removing hot air nozzles Do not over tighten the bolt on the hot air attachments.
- When using the small nozzle attachment for the hot air gun, set airflow to the maximum value to keep the hot air heating element from overheating and breaking.

HOT AIR GUN IN HANDS-FREE TELESCOPIC ASSEMBLY

*NOTE: The hot air gun should **NEVER** be in the vertical position when the unit is initially turned on. It can be used vertically with the appropriate air flow and then should be returned to the side holder for cool down.*



**Hot Air Gun in Hands-Free
Telescopic Assembly**

1. Attach the cord to the side of the machine using the attached clip.
 2. With the nozzle pointing down, insert the hot air gun into the hot air gun holder.
 3. Adjust the bottom silver screws first to center the hot air gun nozzle in the center of the holder.
 4. Adjust the black thumb screws to snugly hold the plastic just above the metal area of the hot air gun to center and secure it in the assembly
- When using the hot air gun in the vertical holder, the air flow must be turned up to at least 4 or higher the **ENTIRE TIME** the hot air gun is in this position. If the air flow is not sufficient the unit will be damaged and the life of the heating element will be greatly reduced.

CAUTION! IF THIS IS NOT FOLLOWED the hot air gun will overheat and may cause the polymer on the front of the hot air gun to melt and get red hot from the intense heat.

- After using the hot air gun, place it back into the side holder, and allow the unit to initiate the cool down cycle until the display reads “---”. Then power can be turned off.
- Always shield the surrounding components while using the hot air gun. Failure to do so could cause other components to become unsoldered and blow off of the board.

FEATURES

CELSIUS / FAHRENHEIT CONVERSION

1. Turn on the power switch(es) for the component(s) that require temperature unit conversion.
2. Press and hold the Hot Air and Iron ↓ buttons simultaneously for 3 seconds, the Hot Air display will show A1.
3. Press the Iron ↓ button and the “C” or “F” will show in the Hot Air and Iron displays.
4. Press the Hot Air ↓ button to change to “F” or the Hot Air ↑ button to change to “C”.
5. Once the desired temperature unit is selected, let the unit stand for 5 seconds. The unit will automatically store the selection.

AUTOMATIC VS. MANUAL MODE FOR HOT AIR GUN

The hot air gun has a built in safety feature where every time the hot air gun is placed in the side holder it will go into Cool Down and Standby Mode. This ensures that the hot air gun is not left running for long periods of time causing undue wear on the unit. This is called Automatic Mode and is enabled for your safety.

The unit does have the option to go into Manual Mode so that the hot air gun will NOT go into Cool Down and Standby Mode when placed in the side holder.

ATTENTION: This unit should ALWAYS be used in Automatic mode for safety purposes. It is very rare that manual mode is needed. Using Manual mode will also greatly reduce the life of the heating element in the hot air gun.

1. Turn on the power switches to the component(s).
2. Press and hold the Hot Air and Iron ↓ buttons simultaneously for 3 seconds, the Hot Air display will show A1.
3. Press the Hot Air ↓ button to change to “0” (Manual Mode) or the Hot Air ↑ button to change to “1” (Automatic Mode).
4. Once the desired conversion is selected, let the unit stand for 5 seconds. The unit will automatically store the selection.

TEMPERATURE CALIBRATION FUNCTION

When is it time to Calibrate your Soldering & Hot Air Station?

All X-Tronic Stations come with a high quality heating element in the soldering iron and hot air gun that are calibrated to within $\pm 1.8^{\circ}\text{F}/1.0^{\circ}\text{C}$ of the temperature that is shown on the LED Display. While calibrating to the exact temperature is the ultimate goal, this heating element and tip/nozzle design are as close as can be achieved with this technology.

The age of the heating element, the hours of use, and the temperature at which the soldering iron/hot air gun are regularly used will affect the life of the heating element and can cause fatigue. When a heating element begins to fatigue, the heat that is transferred to the tip/blowing air from the heating element will begin to drop. If the typical temperature used to solder/desolder is not working as well as when it was new, then it might be time to calibrate the unit.

Notes:

- *The heating elements are a consumable part for soldering irons and hot air guns. There will come a time when the heating element stops working due to age and/or too much deterioration. At this point, it will need to be replaced and cannot be calibrated. Heating elements for this unit can be found on our website (XTronicUSA.com).*
- *For best results, you should only calibrate the temperature for one component at a time.*

CALIBRATION INSTRUCTIONS FOR SOLDERING IRON

1. Turn on the power switch for the soldering iron.
2. Set the desired temperature for the soldering iron on the unit.
3. Let the set temperature stabilize.
4. Measure the heat at the soldering tip using **a high quality and well calibrated soldering tip tester**. If the temperature shown on the unit's display does not reflect the temperature shown on the tester, continue with steps 5-7.
5. Press and hold the up and down buttons for the soldering iron, three decimal points will appear in the temperature display to indicate the soldering iron is in calibration mode.
6. Press the up or down buttons to select the temperature the soldering iron is actually measuring when tested.
7. When the calibrated temperature is set, press the up and down buttons simultaneously to secure the adjusted temperature in memory and exit this mode.

IMPORTANT - PLEASE READ

Infrared (IR) Thermometers should NOT be used to measure the temperature of the soldering tip as they often provide inaccurate readings. All IR Thermometers are different and the capability depends on the Distance to Spot (D:S) ratio of the model being used. Many IR thermometers have a D:S ratio of 8:1 or 12:1 which means that the thermometer needs to be a distance of 8" or 12" in order to read a 1" spot size.

The tip of a soldering iron is approximately 2 to 3 mm (.07-.11"), requiring the thermometer to be 0.8" or 1.2" away from the tip. However, the IR thermometer also has a minimum distance it needs to be away from the object.

Most IR thermometers will not be capable of measuring such a small spot size and will provide disappointing calibration results.

CALIBRATION INSTRUCTIONS FOR HOT AIR GUN

Before measuring the temperature or calibrating the unit, ensure all nozzles have been removed from the hot air gun.

1. Turn on the power switch for the hot air gun.
2. Set the desired temperature for the hot air gun on the unit.
3. Let the set temperature stabilize.
4. Measure the heat of the hot air using a **high quality and well calibrated hot air tester or an infrared thermometer**.
(If using the infrared thermometer, aim it approximately three inches away from the end of the hot air gun.) If the temperature shown on the unit's display does not reflect the temperature shown on the tester, continue with steps 5-7.
5. Press and hold the up and down buttons for the hot air gun, three decimal points will appear in the temperature display to indicate the hot air gun is in calibration mode.
6. Press the up or down buttons to select the temperature the hot air gun is actually measuring when tested.
7. When the calibrated temperature is set, press the up and down buttons simultaneously to secure the adjusted temperature in memory and exit this mode.

MAINTENANCE

UNIT

1. Keep the unit plugged into a grounded outlet at all times while operating.
2. Keep the unit and all of the components free from dirt, debris, and liquid at all times.
3. Make sure the power cord is plugged in correctly into a ground outlet and safely off the floor to prevent accidents.
4. Avoid letting any of the cords hang off the side of the table or workbench keeping them in the immediate workspace.
5. Wipe the unit down, as needed, with a dry, static-free cloth.

SOLDERING TIP PREPARATION & CARE

1. Keep the soldering tip properly tinned. Always use solder with sufficient rosin flux or the tip will degrade. A well tinned tip will be bright all over when hot, with no dull or discolored spots.
2. To tin the iron, do the following:
 - a. Plug in the iron and allow it to reach solder melt temperature.
 - b. Flood the tip with solder and let it stand for one minute.
 - c. Apply more solder to the tip, allow it to idle for one or two more minutes, wipe it lightly on the sponge. Do not remove all of the solder, but use the sponge to remove excess solder and wipe solder onto non-tinned areas.
3. Do not file or attempt to reshape the tip. This will destroy the plating and shorten tip life. Do not use chloride and acid fluxes; they will also shorten tip and heater life.
4. For maximum tip life, always apply solder to the heated connections or joints. Repeated application of solder directly to the tip will shorten the tip life.

WARNING: Do NOT use anti-seize or any other lubricant on the tip retainer or heater of the soldering iron.

CHANGING THE SOLDERING TIP

1. Turn off the soldering station, unplug the power cord from the power source and allow the soldering iron to cool down to room temperature. **Never attempt to remove the tip while the iron is hot.**
2. Unscrew the larger metal tip retaining screw ring at the bottom of the soldering irons metal shaft. Slide off or remove the soldering tip retaining collar. Now, remove the tip by sliding it forward.
3. Slide a new tip over the exposed ceramic heating element, slide the metal retaining collar over the new soldering tip back onto the soldering iron.
4. Tighten the metal tip retaining screw ring to snug the tip into place. Do not over tighten the tip retaining screw
5. Plug the soldering iron AC cord into a grounded outlet to resume soldering.

INSTALL/REMOVE HOT AIR NOZZLES

1. Turn the power off to the unit and unplug it from the power source.
2. Allow the hot air gun and attachment to reach room temperature before proceeding.
3. Do not use excessive force when installing/removing hot air attachments. Loosen the screw and nut from the attachment by holding the nut with a pair of pliers and turning the screw counterclockwise.
4. Slide the attachment off of the metallic shaft of the hot air gun.
5. Repeat in the reverse order for installation. *Do not overtighten the screw and nut on the hot air gun.*

REPLACING THE SOLDERING IRON HEATING ELEMENT

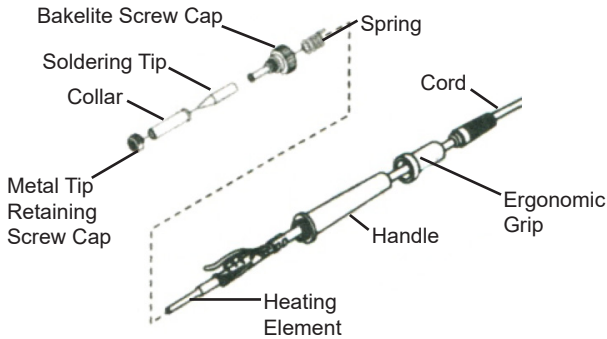

1. Turn off the unit and unplug it from the outlet. Allow the soldering iron to cool down to room temperature.
Never attempt to handle the tip while the iron is hot.
2. Unscrew the Black Bakelite Screw Cap and slide off the full tip assembly.
3. Push the Cord through the bottom of the soldering iron while simultaneously pulling gently on the heating element to expose the heating element circuit board.
4. De-solder the 2 Thin (red or white) wires and the 2 Thick (blue) wires that have heat shielding on them from the circuit board and pull the heating element away from the board. Please take note of the location of the wire thickness/color for installation of new heating element (see diagram below).
5. On one side of the circuit board solder a thin wire to ① and a thick wire to ② (see diagram below).
6. Flip the circuit board over and solder a thin wire to ③ and a thick wire to ④ (see diagram below).
7. Pull the cord back gently and align the circuit board to the slots on the iron so the cord can be pulled back to its original position.
8. Replace black Bakelite Screw Cap and screw back on and hand tighten - **Do NOT over-tighten.**
9. Install the soldering tip, slide the metal soldering tip retaining collar and hand tighten it. Plug the AC cord back into a grounded outlet.

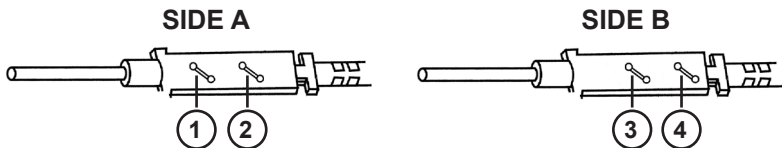

NOTE: The wires on the heating element can be soldered onto either side of the circuit board, as there is no polarity for the element.

REPLACING THE HOT AIR GUN HEATING ELEMENT

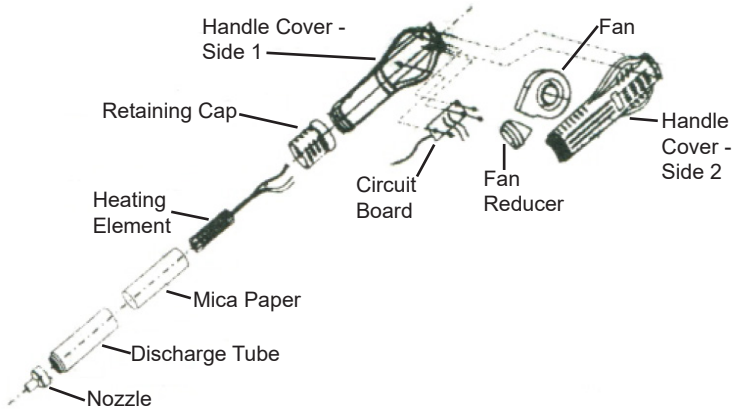

1. Turn off the unit and unplug it from the outlet. Allow the hot air gun to cool down to room temperature.
Never attempt to handle the gun while it is hot.
2. Slide the ergonomic grip up and unscrew the retaining cap, pull the ergonomic grip down off the handle.
3. Unscrew both of the screws at the base of the handle and separate the two handle sides.
4. Pull the heating element out of the Mica Paper and Discharge Tube, being careful not to disconnect grounding wire.
5. Unscrew the two screws holding the circuit board in place.
6. Desolder the four wires to the circuit board - Please take note of the location of the 4 wires thickness/color for installation of new heating element.
7. Solder the new heating element into place.
8. Reassemble the hot air gun.

TROUBLESHOOTING GUIDE

<p>Nothing appears to happen when turning on the unit</p>	<ul style="list-style-type: none"> • Check to ensure that the power cord is securely plugged into the back of the unit and that the unit is plugged into a grounded, working outlet. • Ensure the main power switch on the back of the unit is switched to the on position. • Ensure the appropriate component's power switch is turned on (front of unit). • Check for a blown fuse on the main power input and replace it if needed. • Contact X-Tronic (info on back cover).
<p>Soldering Iron "Rattles"</p>	<ul style="list-style-type: none"> • This is expected behavior. The "rattle" is a small ball that allows the unit to determine when the soldering iron is not in use and it should go into Sleep Mode.
<p>S-E Error</p>	<ul style="list-style-type: none"> • The unit is no longer sensing the element - the heating element may be cracked or worn out and needs to be replaced. Replacements can be purchased on our website: www.XTronicUSA.com.
<p>Soldering tip is not heating up as expected</p>	<ul style="list-style-type: none"> • Ensure the soldering iron is not damaged and in good working condition. • The soldering tip could be oxidized, it is important to always tin the tip and keep it clean. See Soldering Tip Preparation on page 5. • The heating element may need to be replaced. Replacements can be purchased on our website: www.XTronicUSA.com.
<p>Soldering iron is not heating as expected</p>	<ul style="list-style-type: none"> • Ensure the soldering iron is securely attached to the unit. • Soldering tip may need to be tinned • Soldering iron may need to be calibrated. • The heating element may need to be replaced. • Contact X-Tronic (info on back cover).

Hot air gun not heating as expected	<ul style="list-style-type: none"> • Ensure the hot air gun is securely attached to the unit. • The heating element may need to be replaced. • Hot air gun may need to be calibrated • Contact X-Tronic (info on back cover)
IR Preheating plate not getting hot	<ul style="list-style-type: none"> • IR preheating plate may need to be calibrated. • Contact X-Tronic (info on back cover)
No/Insufficient Airflow from Hot Air Gun	<ul style="list-style-type: none"> • Ensure there are no blockages in the nozzle or hot air gun shaft • Adjust the air flow knob to a higher setting • Contact X-Tronic (info on back cover)
Noisy unit	<ul style="list-style-type: none"> • Ensure the unit is on a flat, level surface • Ensure all of the screws and brackets are secure • Contact X-Tronic (info on back cover)

Note: Running the soldering iron in the 600°F ~ 650°F / 315°C ~ 343°C range, which is the normal temperature range for most soldering applications, the heating element should last for 6 to 12 months depending on hours of use.

**X-Tronic
International Inc.**

3-YEAR LIMITED WARRANTY

THIS LIMITED WARRANTY GIVES YOU SPECIFIC LEGAL RIGHTS. YOU MAY ALSO HAVE OTHER RIGHTS, AS THEY VARY FROM STATE TO STATE.

THIS LIMITED WARRANTY CAN ALSO BE FOUND ON OUR WEBSITE AT WWW.XTRONICUSA.COM/SUPPORT/WARRANTY.

WE WARRANT THAT DURING THE WARRANTY PERIOD, THE PRODUCT WILL BE FREE FROM DEFECTS IN MATERIALS AND WORKMANSHIP.

WE LIMIT THE DURATION AND REMEDIES OF ALL IMPLIED WARRANTIES, INCLUDING WITHOUT LIMITATION THE WARRANTIES OF MERCHANTABILITY AND FITNESS FOR A PARTICULAR PURPOSE TO THE DURATION OF THIS EXPRESS LIMITED WARRANTY.

SOME STATES HAVE DIFFERENT LIMITATIONS ON HOW LONG AN IMPLIED WARRANTY LASTS, SO THE ABOVE LIMITATION MAY NOT APPLY TO YOU.

OUR RESPONSIBILITY FOR DEFECTIVE GOODS IS LIMITED TO REPAIR, REPLACEMENT OR REFUND AS DESCRIBED BELOW IN THIS WARRANTY STATEMENT.

WHO MAY USE THIS WARRANTY?

X-Tronic International Inc. located at 2159 Magnum Circle, Lincoln, Nebraska 68522 (“we”) extend this limited warranty only to the consumer who originally purchased the product in the United States, the District of Columbia or Canada (“you”). It does not extend to (a) any subsequent owner or other transferee of the product, (b) any product shipped outside of the United States, the District of Columbia or Canada, or (c) anyone who may have purchased it from someone other than X-Tronic International Inc.. Proof of purchase is required for in-warranty service. We recommend you promptly register this product on our website (www.XTronicUSA.com) to facilitate verification of the date of the original purchase. Keep the product manual and your sales receipt together for future reference.

WHAT DOES THIS WARRANTY COVER?

This limited warranty covers defects in materials and workmanship of the product for the Warranty Period as defined below. In addition, during the Initial Warranty Period, this limited warranty also covers defects occurring in the initial shipment of the product to you.

WHAT DOES THIS WARRANTY NOT COVER?

This limited warranty during the Warranty Period does not cover any damage due to: (a) improper use; (b) failure to follow the product instructions or to perform any preventive maintenance; (c) modifications; (d) unauthorized repair; (e) normal wear and tear that comes with household use; or (f) external causes such as accidents, abuse, or other actions or events beyond our reasonable control. It also does not cover consumable parts.

WHAT IS THE PERIOD OF COVERAGE?

This limited warranty starts on the date of your purchase and lasts for 3 years ("The Warranty Period"), which shall be divided into two periods: (1) the first 30 days from the date of your purchase ("Initial Warranty Period"); and (2) the remainder of the 3 year period after the Initial Warranty Period has expired (the "Remainder Warranty Period"). The Warranty Period is not extended if we repair or replace the product. We may change the availability of this limited warranty at our discretion, but any changes will not be retroactive.

WHAT ARE YOUR REMEDIES UNDER THIS WARRANTY?

With respect to any defective product during the Initial Warranty Period, we will, in our sole discretion either (a) replace such product (or the defective part) free of charge, or (b) refund the purchase price of such product.

With respect to any defective product during the Remaining Warranty Period, we will repair such product free of charge and provide a full-service inspection of your product. You will be responsible for all shipping and handling fees to and from our facility.

HOW DO YOU OBTAIN WARRANTY SERVICE?

To obtain warranty service, you must call 844-861-4762 or email us at Info@XTronicUSA.com during the Warranty Period to open a service request. Proof of purchase will be required to open a service request.

LIMITATION OF LIABILITY

THE REMEDIES DESCRIBED ABOVE ARE YOUR SOLE AND EXCLUSIVE REMEDIES AND OUR ENTIRE LIABILITY FOR ANY BREACH OF THIS LIMITED WARRANTY. OUR LIABILITY SHALL UNDER NO CIRCUMSTANCES EXCEED THE ACTUAL AMOUNT PAID BY YOU FOR THE DEFECTIVE PRODUCT, NOR SHALL WE UNDER ANY CIRCUMSTANCES BE LIABLE FOR ANY CONSEQUENTIAL, INCIDENTAL, SPECIAL OR PUNITIVE DAMAGES OR LOSSES, WHETHER DIRECT OR INDIRECT.

SOME STATES HAVE DIFFERENT LIMITATIONS OF LIABILITY AND EXCLUSIONS, SO THE ABOVE LIMITATION OR EXCLUSION MAY NOT APPLY TO YOU.

QUESTIONS, PROBLEMS OR COMPLIMENTS?

*Thank You for purchasing this
X-Tronic International Product!
We are grateful for your business!*

All of our X-Tronic International Products are inspected then sealed with our NEW Product Seal prior to shipment. Our goal is to ensure Quality, Completeness, and Satisfaction for your order.

**For Any Questions, Problems, or
Compliments please call or email us.**



Toll Free: 844-861-4762



Info@XTronicUSA.com

Our Business Hours are:
Monday - Thursday: 8am - 4pm CST
Friday: 8am - Noon CST

If you would like to shop for other X-Tronic International Products
Please visit our website
www.XTronicUSA.com

X-TRONIC USA

**Soldering Technology
Professionals Can Trust**